



### Selection: Open-Type Reciprocating Compressors

#### Input Values

Compressor model	4T.2Y-K	Useful superheat	100%
Refrigerant	R134a	Motor speed	1450 /min
Reference temperature	Dew point temp.	Drive	Coupling (1:1)
Liq. subc. (in condenser)	0 K	Capacity control	100%
Suction gas temperature	20,00 °C		

#### Result

Q [W]	Cooling capacity	COP [ - ]	COP/EER
Q* [W]	Cooling capacity *	COP* [ - ]	COP/EER *
P [kW]	Power input	m [kg/h]	Mass flow
Qc [W]	Condenser capacity	n [/min]	Compr. speed

tc	to	10°C	5°C	0°C	-5°C	-10°C	-15°C	-20°C	-25°C
30°C	Q [W]	34273	28399	23347	19013	15309	12156	9487	7241
	Q* [W]	34273	28399	23347	19013	15309	12156	9487	7241
	P [kW]	4,84	4,69	4,51	4,28	4,02	3,74	3,43	3,09
	Qc [W]	39113	33091	27852	23294	19332	15894	12913	10334
	COP [ - ]	7,08	6,05	5,18	4,44	3,80	3,25	2,77	2,34
	COP* [ - ]	7,08	6,05	5,18	4,44	3,80	3,25	2,77	2,34
	m [kg/h]	719	591	482	390	313	247	192,3	146,3
	n [/min]	1450	1450	1450	1450	1450	1450	1450	1450
40°C	Q [W]	30392	25139	20616	16734	13413	10588	8198	6189
	Q* [W]	30392	25139	20616	16734	13413	10588	8198	6189
	P [kW]	5,60	5,36	5,08	4,77	4,43	4,05	3,66	3,25
	Qc [W]	35988	30500	25701	21504	17839	14642	11858	9440
	COP [ - ]	5,43	4,69	4,05	3,51	3,03	2,61	2,24	1,90
	COP* [ - ]	5,43	4,69	4,05	3,51	3,03	2,61	2,24	1,90
	m [kg/h]	698	572	466	375	299	235	181,3	136,4
	n [/min]	1450	1450	1450	1450	1450	1450	1450	1450
50°C	Q [W]	26501	21883	17901	14479	11550	9057	6948	5176
	Q* [W]	26501	21883	17901	14479	11550	9057	6948	5176
	P [kW]	6,36	6,04	5,67	5,26	4,82	4,36	3,88	3,39
	Qc [W]	32862	27918	23568	19739	16374	13420	10831	8566
	COP [ - ]	4,17	3,63	3,16	2,75	2,39	2,08	1,79	1,53
	COP* [ - ]	4,17	3,63	3,16	2,75	2,39	2,08	1,79	1,53
	m [kg/h]	675	551	447	359	285	222	169,6	125,9
	n [/min]	1450	1450	1450	1450	1450	1450	1450	1450

-- No calculation possible (see message in single point selection)  
 \*According to EN12900 (20°C suction gas temp., 0K liquid subcooling)

### Application Limits Standard 4T.2

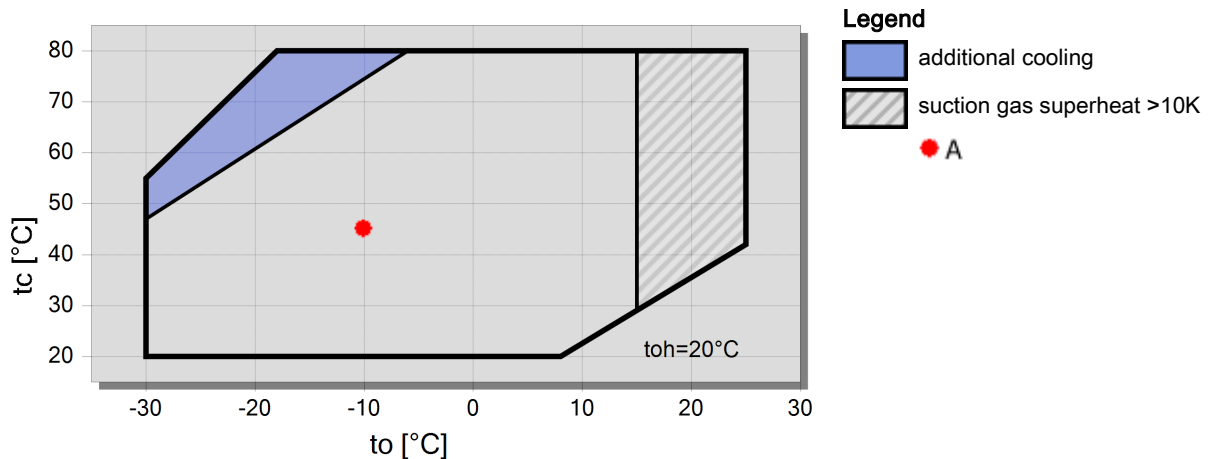



## Technical Data: 4T.2Y-K

### Dimensions and Connections

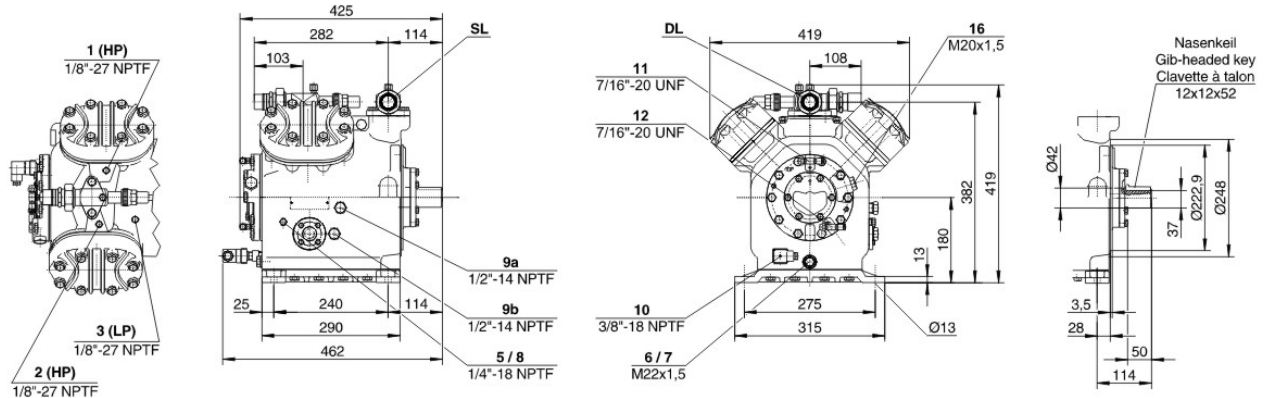

### Technical Data

#### Technical Data

Displacement (1450 RPM 50Hz)	39,36 m3/h
Displacement (1750 RPM 60Hz)	47,5 m3/h
No. of cylinder x bore x stroke	4 x 60 mm x 40 mm
Allowed speed range	750 .. 1750 1/min
Weight	77 kg
Max. pressure (LP/HP)	19 / 25 bar
Connection suction line	35 mm - 1 3/8"
Connection discharge line	28 mm - 1 1/8"
Oil type R134a/R407C/R404A/R507A/R407A/R407F	tc<55°C: BSE32 / tc>55°C: BSE55 (Option)
Oil type R22 (R12/R502)	B5.2 (Standard)

#### Extent of delivery (Standard)

Oil charge	4,0 dm3
Protective charge	Standard
Suction shut-off valve	Standard
Discharge shut-off valve	Standard

#### Available Options

Coupling (...-K) w. A/C + medium	KK411 [<11kW] / KK420 [<22kW] (Option)
Coupling (...-K) w. low temp.	KK415 [<7.5kW] / KK425 [<22kW] (Option)
Coupling housing	Option
Motor pulley (...-S)	190, 210, 230 mm (Option)
V-belts	3 x SPA (Option)
Discharge gas temperature sensor	Option (incl. INT69VS)
Start unloading	Option
Connection cooling water	R 1/2" (Option)
Capacity control	100-50% (Option)
Additional fan	Option
Water-cooled cylinder heads	Option
Oil service valve	Option
Crankcase heater	100 W (Option)
Oil pressure monitoring	MP54 (Option)
Kit for marine application	Option



## Open-Type Reciprocating Compressors

### Motor Selection

The required driving motor is selected for starting conditions at direct start as well as at star-delta- or PW-start with start unloading (bypass + check valve). The starting conditions refer to the following defined operation points resp. to the maximum application limit of the compressor. Should the evaporation- or the condensing temperature of the plant be higher at the start, an individual motor selection is necessary.

Evaporation temperature for motor selection				
	HH	H	M	L
R134a	+20 °C	+12,5 °C	-5 °C	-20 °C
R404A / R507A		+7,5 °C	-5 °C	-20 °C
R407F / R407A				
R22		+12,5 °C	-5 °C	-20 °C
NH <sub>3</sub>	+15 °C	+10 °C	-5 °C	

The stated motor data refer to IEC motors at which the pull-up torque does not fall below 90% of the max. torque. In addition the following starting torques (referring to direct starting torque) must be reached:

- \* 2-cylinder compressors 220 %
- \* 4-cylinder compressors 180 %
- \* 6-cylinder compressors 160 %

Should the motor not fulfil these criteria, an individual selection is also necessary.

### Condenser capacity

The condenser capacity can be calculated with or without heat rejection. This option can be set in the menu Program  Options. The heat rejection is constantly 5% of the power consumption. The condensing capacity is to be found in the line cond.cap. (with HR) resp. cond.cap.

#### Legend of connection positions according to "Dimensions":

- 1 High pressure connection (HP)
  - 2 Connection for discharge gas temperature sensor (HP) (for 4VE(S)-6Y .. 4NE(S)-20(Y) connection for CIC sensor as alternative)
  - 3 Low pressure connection (LP)
  - 4 CIC system: injection nozzle (LP)
  - 4b Connection for CIC sensor
  - 4c Connection for CIC sensor (MP / operation with liquid subcooler)
  - 5 Oil fill plug
  - 6 Oil drain
  - 7 Oil filter (magnetic screw)
  - 8 Oil return (oil separator)
  - 8\* Oil return with NH<sub>3</sub> and insoluble oil
  - 9 Connection for oil and gas equalization (parallel operation)
  - 9a Connection for gas equalization (parallel operation)
  - 9b Connection for oil equalization (parallel operation)
  - 10 Oil heater connection
  - 11 Oil pressure connection +
  - 12 Oil pressure connection -
  - 13 Cooling water connection
  - 14 Intermediate pressure connection (MP)
  - 15 Liquid injection (operation without liquid subcooler and with thermostatic expansion valve)
  - 16 Connection for oil monitoring (opto-electrical oil monitoring "OLC-K1" or differential oil pressure switch "Delta-PII")
  - 17 Refrigerant inlet at liquid subcooler
  - 18 Refrigerant outlet at liquid subcooler
  - 19 Clamp space
  - 20 Terminal plate
  - 21 Maintenance connection for oil valve
  - 22 Pressure relief valve to the atmosphere (discharge side)
  - 23 Pressure relief valve to the atmosphere (suction side)
- SL Suction gas line



DL Discharge gas line

Dimensions can show tolerances according to EN ISO 13920-B.